

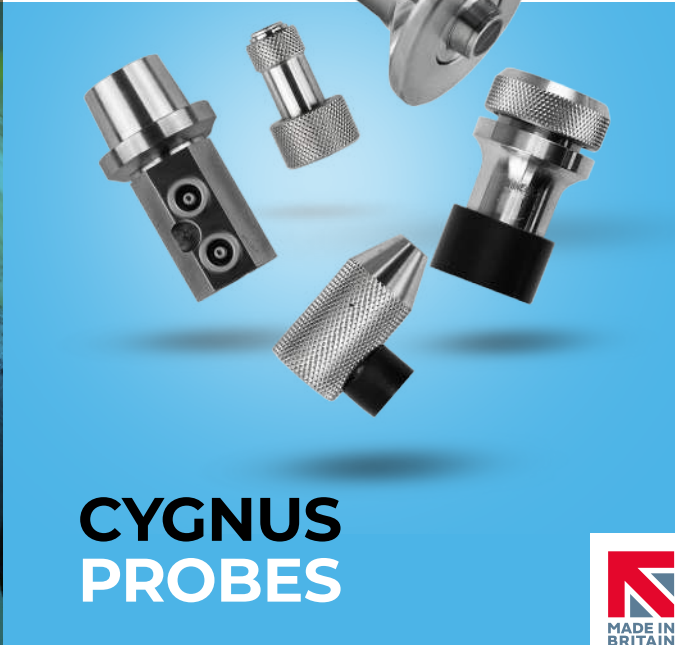

**IDEAL FOR
USE IN**



CYGNUS PROBES



To compliment our ultrasonic thickness gauges we offer a range of ultrasonic probes. The performance of any ultrasonic thickness gauge relies heavily on the probe and its suitability to the material being measured. Therefore, selecting the right probe is vital.



OIL AND
GAS



OFFSHORE
PLATFORMS

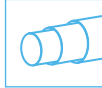

THROUGH
SPECIAL
COATINGS



SHIP
SURVEYS



HIGH
TEMPERATURE

...plant maintenance, civil engineering, marine structures, ship inspections, oil and gas facilities, offshore platforms, wind farms, rail infrastructure, metals protected by thick/special coatings.



EXPLORE CYGNUS
PROBES AND
ACCESSORIES

CYGNUS INSTRUMENTS WHO WE ARE

Trusted by engineers and inspectors worldwide since 1983, Cygnus manufactures truly reliable ultrasonic measurement equipment to suit a broad spectrum of user needs across various industries.

Always taking an application-driven approach, Cygnus has designed its range of surface gauges for ease-of-use, accuracy and with practical functionalities.

Cygnus gauges are renowned for their durability. As such, Cygnus service centres are strategically placed across the globe to provide professional and efficient service throughout the 3-year warranty period and beyond.

CYGNUS INSTRUMENTS PROBES

To compliment our ultrasonic thickness gauges we offer a range of ultrasonic probes. The performance of any ultrasonic thickness gauge relies heavily on the probe and its suitability to the material being measured. Therefore, selecting the right probe is vital.

All Cygnus' probes are made from stainless steel and have a hard wear face or a wear membrane to protect the probe.



EXPLORE THE PROBE RANGE

What does each probe code mean?

Probe Type			Probe Specifics			
Type	Frequency	Crystal Size	Crystal Type	Exit	Connector Type	Application
Single S	0.5 0.5	< 7 A	Monolithic M	Axial A	Wired W	Standard
Twin T	1.00 1	7-11 B	Composite C	Side S	BNC B	High Temp H
	2.00 2	12- 15 C			Lemo - 00 L	Deep Water D
	2.25 2	19 D			uDot U	Boiler Tube B
	3.00 3	25 E			Sub Vis S	Ex X
	3.50 3	30 F				
	4.00 4					
	5.00 5					
	7.50 7					
	10.00 10					
	15.00 15					
20.00 20						

Variety of Cygnus INOX Probes

- Stainless steel TWIN CRYSTAL probes, used in echo-echo and single-echo modes, have improved measurability on extreme back wall corrosion and pitting.
- Stainless steel SINGLE CRYSTAL probes, used in multiple-echo mode, include replaceable membranes for long life, require no zeroing and have a high linear accuracy.
- Probes for use with the Cygnus 2, 2+, 4, 4+ and 6+ gauges are fitted with a BNC or Lemo 00 connector.
- Cygnus DIVE gauge probes are fitted with an integral coiled cable with a Fischer connector.
- Probes for use with the Cygnus Underwater, Intrinsically Safe and Heavy Duty gauges are fitted to a nosecone that screws onto the gauge body.

Guidelines for Probe Frequency Selection

The probe frequency will be determined by the minimum thickness you need to measure. However, the lower the frequency

the more effective the ultrasound will be at penetrating coatings and corrosion. The S2C 2.25 MHz 13 mm (0.5 inch) INOX probe is recommended for the majority of applications as it performs the best on corroded metal and through thick coatings.

Three Versatile Measuring Modes

Multiple-Echo mode uses three error checked back wall echoes to provide the most reliable and accurate remaining thickness measurements, with no need to remove coatings (up to 20mm/0.8 in thick).

Single-Echo mode is ideal for measuring uncoated metals with heavy front and/or back-wall corrosion. Also effective on a range of cast metals, plastics and composites.

Echo-Echo mode works best for measuring heavily corroded metals through thin coatings of up to 1mm/0.04in thick, ideal for measuring painted metals with heavy back wall corrosion.

SURFACE PROBES

Cygnus surface probes are designed for use with the Cygnus Surface range - 2+, 4, 4+ and 6+ Pro.

Single crystal probes are particularly suited to reading through and ignoring coatings.



SINGLE CRYSTAL PROBES

Measuring mode: Multiple-Echo



All surface single crystal probe cables are sold separately.

Right Angle measurement available - please contact Cygnus for more information.

	SSA	S5C	S3C	S2C
	Ideal for: Small diameter pipes and boiler tubes/heat exchangers	Ideal for: Measuring wall thickness down to 1 mm (0.040 inch)	Ideal for: Measuring wall thickness down to 2mm/0.080in with corrosion through coatings	Ideal for: all round measurement of wall thickness with corrosion through coatings
Frequency	5 MHz	5 MHz	3.5 MHz	2.25 MHz
Tip Size	18.60mm (With Knurled Ring)/10mm face	24.90mm (With Knurled Ring)/16mm face	24.90mm (With Knurled Ring)/16mm face	24.90mm (With Knurled Ring)/16mm face
Range in Steel (Multiple-Echo)	1 - 50mm	1 - 50mm	2 - 150mm	3 - 250mm
Weight	27g	65g	65g	65g
Temperature	-10°C to +75°C	-10°C to +75°C	-10°C to +75°C	-10°C to +75°C
Colour	Black Face	Black Band	Orange Band	Red Band

All probes need to be used with Ultrasonic Couplant when taking measurements (excl. underwater)

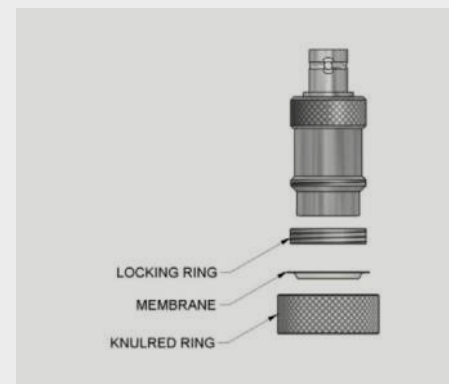

Probe Membrane

Cygnus single crystal probes have a protective membrane fitted in front of the probe face to protect it from damage during use. The membrane also helps the probe face "mould" to surfaces being measured.

The performance of the probe depends on the condition of the membrane and how well it has been fitted. Cygnus recommends membranes are replaced frequently as a precaution or at the first sign of any scoring,

Part No.	Probe Size	Size of Head inc. Knurled Ring (approx.)	Size of Membrane (approx.)
Standard Polyurethane (max. 75°C) Pack of 20			
001-3702	6mm/0.24in	18mm/0.70in	14mm/0.50in
001-3701	13mm/0.50in	24mm/0.95in	21mm/0.82in
001-3700	19mm/0.75in	30mm/1.18in	28.5mm/1.12in
Teflon (max. 150 °C) Pack of 10			
001-4873	6mm/0.24in	18mm/0.70in	14mm/0.50in
001-4874	13mm/0.50in	24mm/0.95in	21mm/0.82in
001-4875	19mm/0.75in	30mm/1.18in	28.5mm/1.12in

A pack of standard membranes is supplied in each gauge kit. Details above to order spares and Teflon membranes.

tearing or damage.

Membranes are available in two materials, the standard Polyurethane membrane is suitable for surface temperatures up to 75°C (167°F), the Teflon membrane is suitable for surface temperatures up to 150°C (302°F) with a maximum contact time of 5 seconds.

Membrane Couplant

Membrane couplant needs to be used between the membrane and the probe face. This creates a thin layer of oil that allows the ultrasound to pass through.

A 25 ml bottle of Membrane Couplant is supplied in each gauge kit.

Knurled Rings And Membrane Locking Ring Keys

Supplied with every single crystal probe, the knurled ring holds the membrane in place. The membrane key is used to unscrew and screw in the locking ring which the membrane is fitted into.

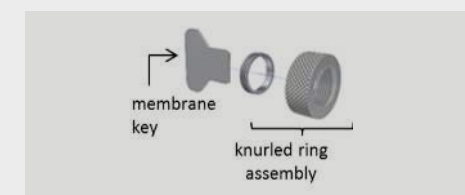

Part Description	Part Number
Knurled Ring Assembly for:	
19mm (0.75 inch) Probes	001-3705
13mm (0.50 inch) INOX Probes	001-3709
13mm (0.50 inch) Probes	001-3704
6mm (0.24 inch) Probes	001-3703
Membrane Keys for:	
19mm (0.75 inch) Probes	001-2610
13mm (0.50 inch) Probes	001-2611
6mm (0.24 inch) Probes	001-2612

Cygnus surface probes are designed for use with the Cygnus Surface range - 2+, 4, 4+ and 6+ Pro.

Twin crystal probes are particularly suited to measuring heavily corroded metals.



SURFACE PROBES

TWIN CRYSTAL PROBES

Measuring mode: Echo-Echo and Single-Echo



	Cables sold separately		Probes come with cable attached		
	T2C Ideal for: Attenuative materials Cast irons, Plastics	T5B Ideal for: General purpose Most metals	T7A-CSWB Ideal for: Thin metals	T5B-CSW Ideal for: General purpose Most metals	T5A Ideal for: General purpose Most metals
Frequency	2 MHz	5 MHz	7.5 MHz	5 MHz	5 MHz
Tip Size	17mm	13mm	6.4mm	13mm	9.5mm
Range in Steel (single Echo)	2.5-250mm	1.5-200mm	0.8-50mm	1.5-200mm	1.5-150mm
(Echo-Echo)	5-50mm	4-50mm	3-25mm	4-50mm	4-50mm
Weight	59g	61g	71g (Includes fixed cable)	61g	85g (Includes fixed cable)
Temperature	-10°C to +75°C	-10°C to +75°C	-10°C to +75°C	-10°C to +75°C	-10°C to +75°C
Colour	Blue Band	Yellow Band	N/A	Yellow Band	N/A

All probes need to be used with Ultrasonic Couplant when taking measurements (excl. underwater)

Visit cygnus-instruments.com to explore our full product range

HOW TO CHOOSE THE RIGHT PROBE

WHAT ARE YOU TESTING?

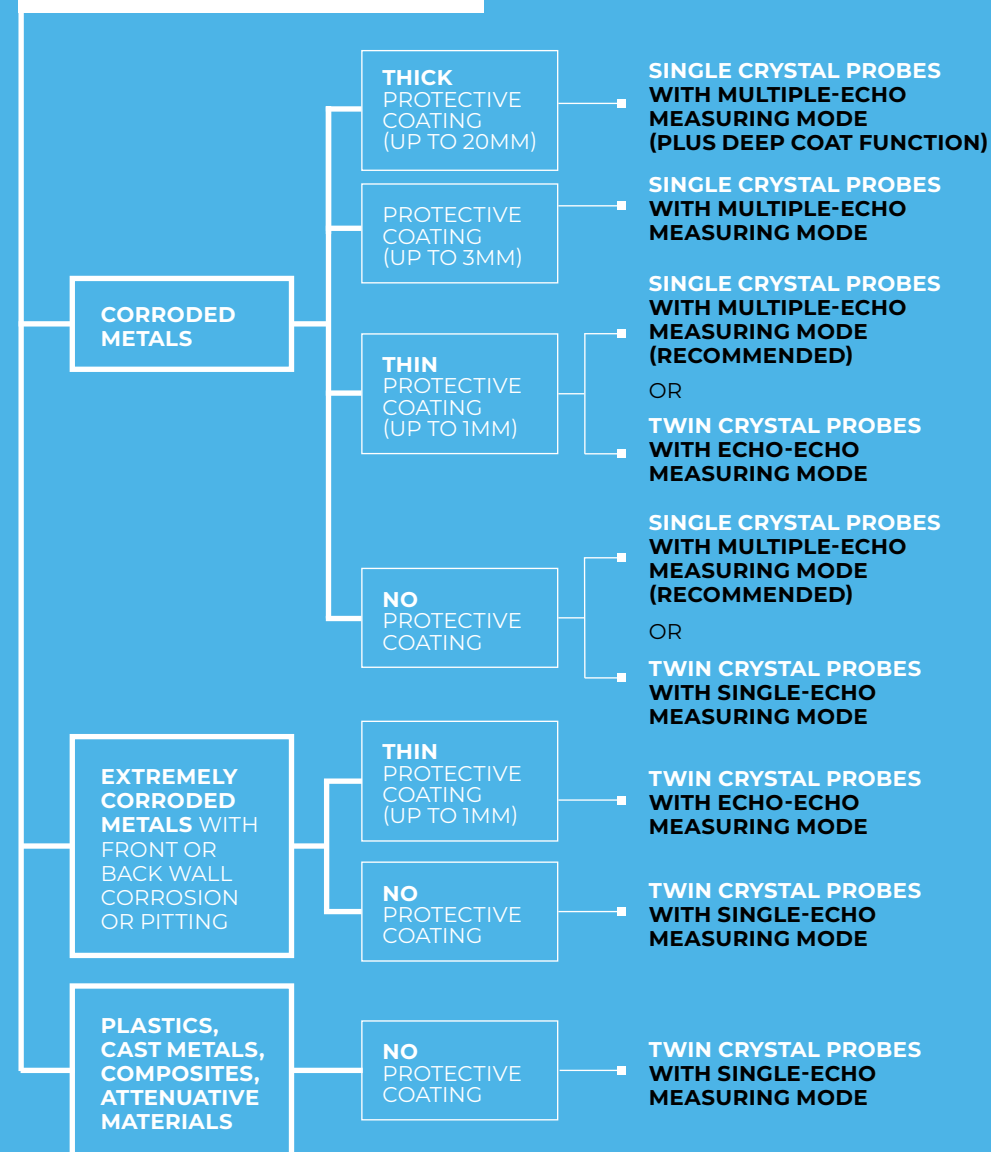

Call our team today on +44 (0) 1305 265 533 for expert product advice

CYGNUS 1 EX PROBES

Cygnus 1 Ex probes are specifically designed for exclusive use with the Cygnus 1 Ex gauge.

Like the gauge, each probe is certified to ATEX, IECEx and UKEx for use in Zone 0 areas, for safe use in all hazardous gas Zones (0, 1, 2), combustible dust Zones (21, 22) and coal mines.



SINGLE CRYSTAL EX PROBES

Measuring mode:
Multiple-Echo



All Ex probes come with cable attached

	S2C-Ex Ideal for: General purpose probe suitable for most applications that can use Multiple Echo measurement. Coated metals.	S3C-Ex Ideal for: Coated metals	S5A-Ex Ideal for: Coated metals
Frequency	2.25 MHz	3.5 MHz	5 MHz
Tip Size	24.90mm (With Knurled Ring)/16mm face	24.90mm (With Knurled Ring)/16mm face	18.60mm (With Knurled Ring)/10mm face
Range in Steel (Multiple-Echo)	3-250mm	2-150mm	1-50mm
Colour	Red Band	Orange Band	Black Band

All probes need to be used with Ultrasonic Couplant when taking measurements (excl. underwater)

TWIN CRYSTAL EX PROBES

Measuring mode:
Echo-Echo and
Single-Echo



All Ex probes come with cable attached

	T7A-Ex Ideal for: Thin metals	T5A-Ex Ideal for: General purpose Most metals	T5B-Ex Ideal for: General purpose Most metals	T2C-Ex Ideal for: Attenuative metals Cast irons, Plastics
Frequency	7.5 MHz	5 MHz	5 MHz	2 MHz
Tip Size	6.4mm	9.5mm	13mm	17mm
Range in Steel (Single-Echo)	0.8-50mm	1.5-150mm	1.5-200mm	2.5-250mm
(Echo-Echo)	3.25mm	4-50mm	4-50mm	5-50mm
Colour	N/A	N/A	Yellow	Blue

All probes need to be used with Ultrasonic Couplant when taking measurements (excl. underwater)

Visit cygnus-instruments.com to explore our full product range

Call our team today on +44 (0) 1305 265 533 for expert product advice

HIGH TEMPERATURE PROBES

The Cygnus High Temperature Probe is designed for use with Cygnus 4+ and 6+ Pro gauges. The High Temperature Ex Probe is specifically for use with Cygnus 1 Ex.

No cooling period is required - reducing inspection time and facilitating more effective measurement.



HIGH TEMPERATURE PROBE

Measuring mode: Echo-Echo and Single-Echo



Cygnus' Twin Element Ultrasonic Probes are designed for high-temperature, in-service corrosion surveys and wall thickness measurements on hot surfaces up to 300°C.

Option to use a standard cable or a more robust, braided cable.



Standard Cable

Braided Cable

Cables sold separately

T5B-MAUH

Ideal for: hot surfaces up to 300°C

Frequency	5.0 MHz, 8mm (0.31in) Nominal
Tip Size	12mm tip/9mm face
Range in Steel (Single-Echo)	1.5-150mm (Ambient temperature)
(Echo-Echo)	4-50mm (Ambient Temperature)
Weight	100g
Temperature Range	-55°C to 300°C (-67°F to 572°F)

High Temperature Ultrasonic Couplant is required when taking measurements

Visit cygnus-instruments.com to explore our full product range

HIGH TEMPERATURE EX PROBE

Measuring mode: Echo-Echo and Single-Echo



ATEX-certified high temperature probe for measuring hot surfaces up to 300°C (570°F) continuous. **No cooling period required** - reducing inspection time and facilitating more effective measurement.

The probe is designed for use with a special probe cable wrapped in a glass-fibre outer braid to protect the cable.



The probe and probe cable are sold separately, enabling lower replacement costs.



Cables sold separately

Ex-HTP

Ideal for: hot surfaces up to 300°C

Frequency	5.0 MHz
Tip Size	12mm tip/9mm face
Range in Steel (Single-Echo)	1.5-150mm (Ambient temperature)
(Echo-Echo)	4-50mm (Ambient Temperature)
Temperature Range	-10°C to 300°C (14°F to 572°F)

High Temperature Ultrasonic Couplant is required when taking measurements

Call our team today on +44 (0) 1305 265 533 for expert product advice

SUBSEA PROBES

Cygnus subsea probes are overmoulded with a coloured ring to indicate the probe type and are constructed from stainless steel. They are designed for use with Cygnus Subsea Range - Dive, Underwater, ROV Mini and ROV UTM. There are also options compatible with Cygnus probe handlers.

Single crystal probes are particularly suited to reading through and ignoring coatings. Twin crystal probes are particularly suited to measuring heavily corroded metals.



SINGLE CRYSTAL PROBES

Measuring mode:
Multiple-Echo



All subsea probes come with cable attached

	S2C	S3C	S5C	S5A
	Ideal for: General purpose probe suitable for most applications that can use Multiple Echo measurement. Coated metals	Ideal for: Coated metals	Ideal for: Small diameter tubes. Thin metals. Coated metals	Ideal for: Coated metals
Depth Rating	300 metres	300 metres	300 metres	300 metres
Frequency	2.25 MHz	3.5 MHz	5 MHz	5 MHz
Tip Size	24.90mm (With Knurled Ring)/16mm face	24.90mm (With Knurled Ring)/16mm face	24.90mm (With Knurled Ring)/16mm face	18.60mm (With Knurled Ring)/10mm face
Range in steel (Multiple-Echo)	3-250mm	2-150mm	1-50mm	1-50mm
(Single-Echo)	N/A	N/A	N/A	N/A
(Echo-Echo)	N/A	N/A	N/A	N/A
Weight	234g (Includes fixed cable)	3234g (Includes fixed cable)	234g (Includes fixed cable)	188g (Includes fixed cable)
Temperature Range	-10°C to +75°C	-10°C to +75°C	-10°C to +75°C	-10°C to +75°C
Colour	Red	Orange	Black	Black



Cable attached

	SD2C
	For use only with the ROV-UTM system, this Single Element Delay Line probe can be used in SE, EE and ME modes
Depth Rating	3000 metres
Frequency	2.25 MHz
Tip Size	15.5mm
Range in steel (Single-Echo)	4-20mm
(Echo-Echo)	4-50mm
(Echo-Echo)	4-30mm
Weight	1832g (Includes fixed cable)
Temperature Range	-10°C to +100°C
Colour	N/A

TWIN CRYSTAL PROBES

Measuring mode:
Echo-Echo and Single-Echo



Cable attached

	T5B	T2C
	Ideal for: General purpose. Most metals	Ideal for: Attenuative materials. Cast irons. Plastics
Depth Rating	50 metres	50 metres
Frequency	5 MHz	2 MHz
Tip Size	13mm	17mm
Range in steel (Single-Echo)	1.5-200mm	2.5-200mm
(Echo-Echo)	4-50mm	5-50mm
Weight	224g (Includes fixed cable)	220g (Includes fixed cable)
Temperature Range	-10°C to +75°C	-10°C to +75°C
Colour	Yellow	Blue



Cygnus Instruments Ltd.
 Cygnus House
 30 Prince of Wales Road
 Dorchester
 Dorset DT1 1PW
 United Kingdom



ISS2 04/26

All information provided is subject to change without prior notice.

Cygnus Headquarters

Call +44 (0) 1305 265 533
 Email sales@cygnus-instruments.com
 Visit cygnus-instruments.com

Cygnus UAE

Call +971 50 3459305
 Email ribu@cygnus-instruments.com
 Visit cygnus-instruments.com

Cygnus USA

Call +1 346 223 0415
 Email sales@cygnus-instruments.com
 Visit us.cygnus-instruments.com

Cygnus Singapore

Call +65 6252 5909
 Email sales@cygnus-instruments.sg
 Visit sg.cygnus-instruments.com